



Battery Operated (3x AA)



Stackable Design for easy and safe storage



Load cell lock

SH SERIES

Basic Weighing Scale

SH series is a simple weighing scale which offers high product versatility and reliability. Its simple design makes it easy to use and furthermore, its compact design and battery operation makes it ideal for use anywhere.

- Load cell lock & adjustable footing
- Easy-to-use compact scale
- Stackable design
- Battery operated (3x AA)



CAS

SH SERIES | Basic Weighing Scale

Stackable Design

A molded stacking ring under the SH series allows several scales to be stacked in storage without slipping.



Load cell lock & adjustable footing

The load cell lock engineering protects the SH scale series during transport and storage, while the adjustable footing provides greater stability.

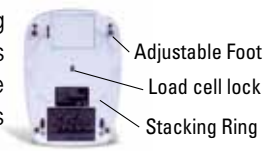

AC adapter or battery power

Power the SH series by AC adaptor or AA alkaline batteries for approx. 300hrs of usage. Combined with its compact design the SH series ideal for use anywhere.



Specifications

TECHNICAL DATA

Model	SH Series		
Max. Capacity (g)	200	2,000	5,000
Readability (g)	0.1	1	2
External Resolution	1/2,000		1/2,500
Weighing Units	g, oz	g, lb: oz, oz t, dw t	
Display Digit	6 Digits (weight)		
Display Type	LCD		
Operating Temp.	-18°C ~ 25°C		
Power	3x AA batteries		
Battery Life	300hrs		
Pan Size (mm)	120		
Dimensions (mm)	145(W) x 45(D) x 205(H)		
Product Weight (kg)	0.4		

FEATURES

- Load cell lock function
- Possible to stack in storage without slipping
- Simple & easy to operate
- High contrast LCD display
- Battery or AC adapter operation
- Auto power-off for low energy consumption
- Over / under load indicator

DIMENSIONS

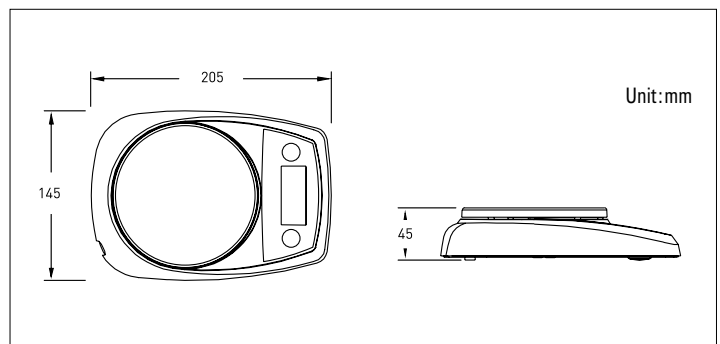

OPTIONS

- AC adaptor

CAS

CAS NEW ZEALAND LTD
 MANUKAU CITY 2104
 AUCKLAND, NEW ZEALAND
 EMAIL: sales@casscale.co.nz
<http://www.cassscale.co.nz>

Specifications are subject to change for improvement without prior notice.



Sensortronic Scales

Service & Calibration | Customised Solutions | Weighing Equipment

Free Phone: 0800 4 SCALES
Email: sales@sensortronicscales.co.nz